

Part type designation	Part number
GSP274	00019756-00
GSP274 CC	00021759-00



GSP274 Grid Measurement, Synchronization and Protection Module

The GSP274 module enables the safe, reliable and automatic synchronization of generator units to the power supply grid. It also provides a number of monitoring functions for generator and grid protection. The circuit-breakers are tripped by the module directly via digital outputs and relays. Additional digital inputs enable the monitoring of the relevant switching state. The continuous monitoring of grid harmonics up to the 50th harmonic can be used for direct reactions as well as for evaluating the power quality.

The module is provided with an integrated real-time data recorder for the high-precision recording of up to 16 measuring channels during protective tripping or synchronization. Error events are recorded continuously and stored permanently with a high resolution time stamp. The internal time base of the module can be synchronized to an external time source (e.g. IEEE 1588 Precision Time Protocol), which supports the analysis of the data from spatially separated measurement and protection devices.

The module is fully integrated in the Bachmann SolutionCenter. Configurations can be created simply and stored for later reuse. Both the measured channel values and also the derived values are made available directly in the user interface. Commissioning and fault analysis are simplified with tabular, vector and time sequence displays. Event logs and recorded time sequences can be exported in CSV respectively COMTRADE format. The integrated simulation function simplifies the configuration of protection and monitoring functions.

Features

- Measurement of current, voltage, frequency, power, power factor, phase angle
- Measurement of grid harmonics up to the 50th (power quality)
- Synchronization monitoring / Synchro-check
- Monitoring functions for grid and generator protection
- Controls two circuit breakers
- Integrated real-time data recorder
- Integrated event logging
- 4Q energy meter
- Measured value simulation

GSP274 – Grid measurement

Current/voltage measurement	
Measuring method	True RMS (incl. harmonics up to 3 kHz) Fundamental RMS (only fundamental)
Sampling rate	100 μ s (10 kHz)
Measurement interval	50 Hz: 10 ms 60 Hz: 8.33 ms
Individual samples	Intervals that can be retrieved via function calls in the user application: 100 μ s, 200 μ s, 400 μ s, 800 μ s, 1.6 ms (via block access)

Voltage measurement	
Number	7 (generator: L1,L2,L3,N/grid: L1,L2,L3,N/busbar Lx,Ly)
Maximum rated voltage	$U_{L-L, RMS}$: 480 V_{RMS} $U_{L-N, RMS}$: 277 V_{RMS}
Voltage measuring range	$U_{L-L, RMS}$: 5 V_{RMS} to 718 V_{RMS} , $U_{L-N, RMS}$: 3 V_{RMS} to 415 V_{RMS}
Accuracy ¹⁾	$\leq \pm 0.15$ %
Continuous overload	$U_{L-L, RMS}$: 1021 V_{RMS} , $U_{L-N, RMS}$: 590 V_{RMS}
Short-term overload (10x10 s, interval 10 s)	$U_{L-L, RMS}$: 3637 V_{RMS} , $U_{L-N, RMS}$: 2100 V_{RMS}
Input impedance	> 2 M Ω

¹⁾ Accuracy rating as a percentage of the nominal value at 25 °C and reference conditions

Current measurement	
Number	4 (generator: 3x, Generator star/neutral-point: 1x)
Accuracy ¹⁾	$\leq \pm 0.08$ %
Current transformer rated current	5 A_{RMS}
Current measuring range	0.01 A_{RMS} to 9.5 A_{RMS}
Response threshold	1 mA
Continuous overload	10 A_{RMS}
Short-term overload (5x1 s, interval 300 s)	100 A_{RMS}
Burden	250 mVA

¹⁾ Accuracy rating as a percentage of the nominal value at 25 °C and reference conditions

Frequency measurement	
Rated frequency	50/60 Hz
Reference range	50 Hz: 35 Hz to 65 Hz 60 Hz: 45 Hz to 75 Hz
Accuracy ¹⁾	$\leq \pm 0.004$ Hz
Measurement interval	Updated at each positive zero crossing 1-phase system: 3-phase system: 50 Hz: 20 ms 50 Hz: 6.667 ms 60 Hz: 16.67 ms 60 Hz: 5.6 ms
Frequency change measurement	Yes

¹⁾ Accuracy rating as a percentage of the nominal value at 25 °C and reference conditions

GSP274 – Grid measurement

Phase measurement, asymmetry	
Phase shift	Angles from current phasor to voltage phasor for each phase
Voltage system	Angles between the voltage phasors
Asymmetry voltage system	Quotient of negative and positive sequence system of voltages or nominal voltage as percent value
Asymmetry current system	Quotient of negative and positive sequence system of currents or nominal current as percent value
Field rotation direction	Detection for voltage and current system

Power measurement – active, reactive and apparent power	
Measured values	P, Q, S per phase and as total value
Accuracy ¹⁾	≤ ±0.2 %
Calculation methods	DIN 40110-2, IEC 61400-21
Measurement interval	Updated at each positive zero crossing
	1-phase system: 3-phase system:
	50 Hz: 20 ms 50 Hz: 6.667 ms
	60 Hz: 16.67 ms 60 Hz: 5.6 ms

¹⁾ Accuracy rating as a percentage of the nominal value at 25 °C and reference conditions

Energy	
Accuracy ¹⁾	≤ ±0.2 %
Resolution	1 Ws
Active energy	Supplied (positive), drawn (negative)
Reactive energy	Supplied (positive), drawn (negative)
Type of memory	Nonvolatile (on the module)
Measurement interval	Updated at each positive zero crossing
	1-phase system: 3-phase system:
	50 Hz: 20 ms 50 Hz: 6.667 ms
	60 Hz: 16.67 ms 60 Hz: 5.6 ms

¹⁾ Accuracy rating as a percentage of the nominal value at 25 °C and reference conditions

Power quality	
Voltage	Total harmonic distortion (THD) per phase
Current	Total demand distortion (TDD) per phase
Voltage harmonics	Amplitudes of harmonics up to 50th harmonic per phase
Current harmonics	Amplitudes of harmonics up to 50th harmonic per phase
Calculation method	EN 61000-4-7
Measurement interval	50 Hz: Calculation over 10 cycles 60 Hz: Calculation over 12 cycles

Digital inputs – switch position indication	
Number	4 (2 groups each with 2 inputs)
Signal nominal voltages	24 V DC
Input voltage range (H)	15 V DC to 34 V DC
Input voltage range (L)	-34 V DC to 5 V DC
Internal resistance	6.8 kΩ
Input delay (typ.)	1 ms
Status indication (LED)	Green

GSP274 – Grid measurement

Digital outputs – synchronization and alarming	
Number	4
Signal nominal voltages	24 V DC
Output voltage range (H)	18 V DC to 34 V DC
Output current max.	0.5 A
Status indication (LED)	Green
Digital relay outputs – grid and system protection	
Number/type	2 changeover contacts
Signal nominal voltages	230 V AC, 48 V DC, 24 V DC (not mixed)
Output current max.	Nominal 0.5 A at +24 V DC, DC13 Nominal 0.5 A at +24 V DC, resistive load Nominal 1 A at 230 V AC, AC15 Nominal 2 A at 230 V AC, resistive load
Status indication (LED)	Green

GSP274 – limit value monitoring

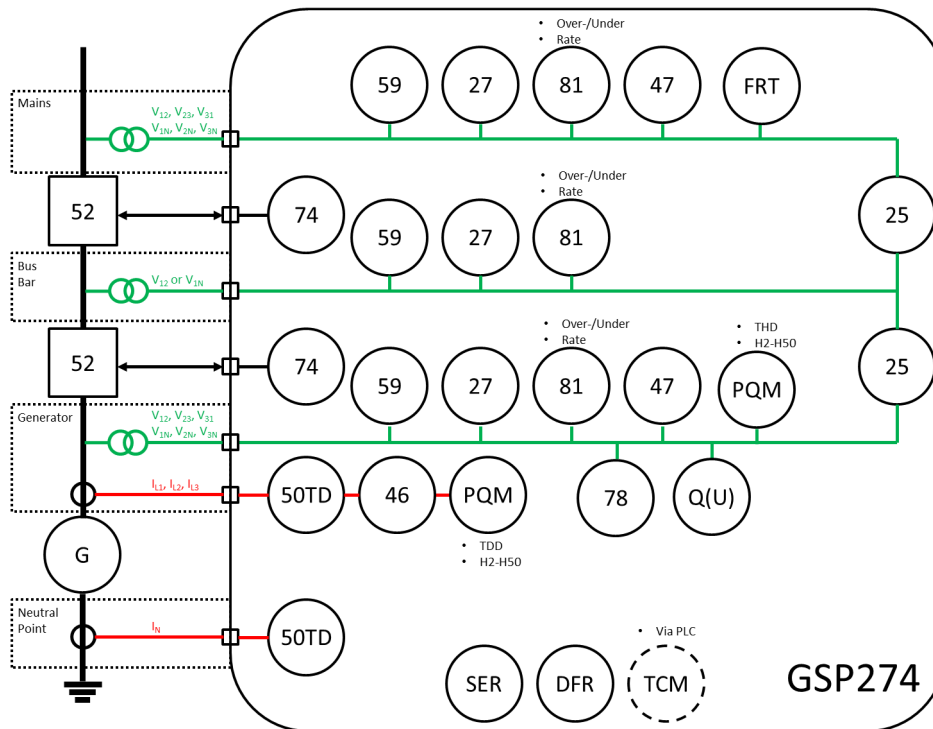

Available protection elements acc. to ANSI IEEE Std C37.2 – 2008 – overview

GSP274 – limit value monitoring

Undervoltage/Overvoltage (ANSI 27/59)													
Resolution	0.1 % U_{nom}												
Delay	0 ms to 65 535 ms												
Evaluated potentials	Phase-to-phase or phase-to-neutral												
Protection elements	<table border="0"> <tr> <td>U<</td> <td>Undervoltage warning</td> </tr> <tr> <td>U<<</td> <td>Undervoltage error</td> </tr> <tr> <td>U></td> <td>Overvoltage warning</td> </tr> <tr> <td>U>></td> <td>Overvoltage error</td> </tr> </table>	U<	Undervoltage warning	U<<	Undervoltage error	U>	Overvoltage warning	U>>	Overvoltage error				
U<	Undervoltage warning												
U<<	Undervoltage error												
U>	Overvoltage warning												
U>>	Overvoltage error												
Underfrequency/Overfrequency (ANSI 81 U/O)													
Delay	0 ms to 65 535 ms												
Protection elements	<table border="0"> <tr> <td>f<</td> <td>Underfrequency inner band</td> </tr> <tr> <td>f<<</td> <td>Underfrequency middle band</td> </tr> <tr> <td>f<<<</td> <td>Underfrequency outer band</td> </tr> <tr> <td>f></td> <td>Overfrequency inner band</td> </tr> <tr> <td>f>></td> <td>Overfrequency middle band</td> </tr> <tr> <td>f>>></td> <td>Overfrequency outer band</td> </tr> </table>	f<	Underfrequency inner band	f<<	Underfrequency middle band	f<<<	Underfrequency outer band	f>	Overfrequency inner band	f>>	Overfrequency middle band	f>>>	Overfrequency outer band
f<	Underfrequency inner band												
f<<	Underfrequency middle band												
f<<<	Underfrequency outer band												
f>	Overfrequency inner band												
f>>	Overfrequency middle band												
f>>>	Overfrequency outer band												
Q(U)													
Description	Voltage dependent directional reactive power protection. Used to support the voltage during grid faults. Trips if all 3 evaluated voltages are below a certain limit (e.g. $0.85 U_{nom}$) and inductive reactive power is drawn from the power supply grid.												
Rate of change of frequency – ROCOF (ANSI 81 R)													
Description	To calculate the frequency change over time the last 10 (50 Hz) or 12 (60 Hz) frequency samples are linearly interpolated.												
Vector shift (ANSI 78)													
Description	Monitoring of sudden phase shifts for detection of sudden load changes or islanding.												
Overcurrent (ANSI 50TD)													
Resolution	0.1 % of I_{nom}												
Delay	0 ms to 65 535 ms												
Protection elements	<table border="0"> <tr> <td>I></td> <td>Overcurrent warning</td> </tr> <tr> <td>I>></td> <td>Overcurrent error</td> </tr> </table>	I>	Overcurrent warning	I>>	Overcurrent error								
I>	Overcurrent warning												
I>>	Overcurrent error												
Time-dependent undervoltage/overvoltage protection (VFRT)													
Description	<p>Time-dependent voltage monitoring is triggered if one of the three phase voltages (asymmetrical fault) or all voltages (symmetrical fault) fall below or rise above a curve $U(t)$ configured via interpolation points. Up to 11 time/voltage pairs are available to calculate a grid-code dependent limit curve.</p> <p>Four separate protection functions can be used with different parameter sets. (LVRT, HVRT)</p>												
Protection elements	<table border="0"> <tr> <td>$U(t)_{a>}$, $U(t)_{b>}$, $U(t)_{c>}$, $U(t)_{d>}$,</td> </tr> <tr> <td>$U(t)_{a<}$, $U(t)_{b<}$, $U(t)_{c<}$, $U(t)_{d<}$</td> </tr> </table>	$U(t)_{a>}$, $U(t)_{b>}$, $U(t)_{c>}$, $U(t)_{d>}$,	$U(t)_{a<}$, $U(t)_{b<}$, $U(t)_{c<}$, $U(t)_{d<}$										
$U(t)_{a>}$, $U(t)_{b>}$, $U(t)_{c>}$, $U(t)_{d>}$,													
$U(t)_{a<}$, $U(t)_{b<}$, $U(t)_{c<}$, $U(t)_{d<}$													

GSP274 – limit value monitoring**Voltage asymmetry monitoring (ANSI 47TD)**

Description	Monitoring of the actual asymmetry of the voltage system against the given threshold value. The asymmetry calculation can be configured as ratio of the actual negative sequence voltage to the actual positive sequence voltage (EN 50160) or to the nominal voltage.
-------------	--

Current asymmetry monitoring (ANSI 46)

Description	Monitoring of the actual asymmetry of the current system against the given threshold value. The asymmetry calculation can be configured as ratio of the actual negative sequence current to the actual positive sequence current (EN 50160) or to the rated current.
-------------	--

Power quality monitoring – PQM

Description	Monitors voltage and current harmonics up to the 50th harmonic. Trips if one of the pre-defined limits is exceeded (evaluation per phase).	
Protection elements	THD	Total harmonic distortion
	TDD	Total demand distortion
	H ₂ to H ₅₀	Individual amplitudes of voltage harmonics
	H ₂ to H ₅₀	Individual amplitudes of current harmonics

Alarm relays (ANSI 74)

Description	Two relays for actuating the circuit-breakers are provided for single fault tolerant grid and system protection acc. to VDE-AR-4105. See "Digital relay outputs"
-------------	--

Synchronization test relays (ANSI 25)

Description	Digital outputs control up to two circuit breakers (2 DO per circuit breaker). They are activated by the GSP module if the synchronization criteria are fulfilled. Pulse or continuous signal can be configured for the actuation. See "Digital Outputs"
Black bus start	Yes

Trip circuit monitoring – TCM

Description	Digital inputs are provided to monitor the actual switching state of the circuit breakers. See "Digital Inputs"
-------------	---

Time synchronization

Basic principle	The GSP module is synchronized automatically with the real-time clock of the PLC-CPU. This one can be time synchronized via the network.
Physical medium	Ethernet (CPU)
Protocols	IEEE 1588 PTP (Precision Time Protocol) SNTP (Simple Network Time Protocol)

Event logging with real-time stamp – SER (sequence of events recorder)

Description	Monitoring events (configured alarm/protection functions) are stored with a precise time reference when they occur.
Type of memory	Nonvolatile (on the module)
Size	2048 entries

GSP274 – limit value monitoring

Real-time data recorder / digital fault recorder – DFR

Description	The GSP module is provided with 3 integrated real-time data recorders. One data recorder can be used for recording the synchronization sequence between the generator and busbar and one for busbar and grid. Another data recorder can carry out recordings when triggered by a monitoring function.
Number of channels	16 channels (measured values, digital I/O, calculated values)
Memory depth per channel	40 960 samples (4 s at 100 µs sampling rate)
Sampling rate	100 µs, 200 µs, 400 µs, 800 µs, 1.6 ms
Pre-trigger	Yes

GSP274 – module properties

Electrical safety

Product standard	IEC/EN 61131-2
Generic standard	IEC/EN 60664-1
Pollution degree (IEC 60664-1)	2
Overvoltage category	III
Rated impulse voltage	5 kV
Protection class	2

Approvals/Certificates

Generator grid connection	GER: VDE-AR-N 4105:2018, DIN VDE V 0124-100:2020, VDE-AR-N 4110:2018, FGW TR3 (Rev. 25), FGW TR8 (Rev. 9) UK: ENA G99/1/4:2019 USA: IEEE C37.90:2005
Maritime & Offshore	ABS, BV, DNV, LR, KR, NK, RINA

Environmental conditions

Operating temperature	-30 °C to +60 °C (standard mounting position)
Relative humidity, operation	5 % to 95 % noncondensing
Storage temperature	-40 °C to +85 °C
Relative humidity, storage	5 % to 95 % noncondensing
Maximum altitude	2000 m above Operation up to 4500 m on request

Power supply

Via backplane	+5 V ≤ 316 mA, +15 V ≤ 21 mA, -15 V ≤ 23 mA
External on the module	24 V 110 mA

System requirements

Hardware	All M200 CPU families apart from ME203, SK1 backplane not required
Software	Recommended: M-Base V4.25 / SolutionCenter V2.25 or higher At least M-Base V3.90 / SolutionCenter V1.90 or higher (with restrictions)

Order data

Part type designation	Part number	Description
GSP274	00019756-00	Grid measurement, protection and synchronization module 7x In 480 V, 4x In 5 A; 4x In 24 V DC; 4x Out 24 V DC; 2x Out Relay 24/48 V DC, 230 V AC; U-, I-, P-, Q-, f-measurement; 4Q-energy metering, integrated monitoring/protection functions, harmonic analysis, integrated disturbance recorder (16 channels); sequence of event log with real-time stamp
GSP274 CC	00021759-00	GSP274; ColdClimate (❄️)

Accessories

Part type designation	Part number	Description
KZ-GSP274 B+C	0002342600	Terminal set Phoenix cage clamp/screw (1x KZ 51/03; 3x KZ 51/06; 2x SS76/10) with labeling strips + keying elements