

Item	Item-No.
GSP274	00019756-00
GSP274 CC	00021759-00

GSP274 Grid Measurement, Synchronization and Protection Module

The GSP274 enables the safe, reliable and automatic synchronization of generator units to the power supply grid. It also provides a number of monitoring functions for generator and grid protection. The circuit-breakers are tripped by the module directly via digital outputs and relays. Additional digital inputs enable the monitoring of the relevant switching state. The continuous monitoring of grid harmonics up to the 50th harmonic can be used for direct responses as well as for evaluating the power quality.

The module is provided with an integrated real-time data recorder for the high-precision recording of up to 16 measuring channels during protective tripping or synchronization. Error events are recorded continuously and stored permanently with a high resolution time entry. The internal time base of the module can be synchronized to an external time source (e.g. IEEE 1588 Precision Time Protocol), which supports the analysis of the data from spatially separated measurement and protection devices.

The GSP274 is fully integrated in the Bachmann SolutionCenter. Configurations can be created simply and stored for later reuse. Both the measured channel values and also the derived values are made available directly in the user interface. Commissioning and fault analysis are simplified with tabular, phasor and time sequence displays. Event logs and recorded time sequences can be exported in CSV respectively COMTRADE format. The integrated simulation function simplifies the configuration of protection and monitoring functions.

- Measurement of current, voltage, frequency, power, power factor, phase angle
- Measurement of grid harmonics up to the 50th (power quality)
- Synchronization monitoring / Synchro-check
- Monitoring/Protection functions for grid and generator protection
- Controls two circuit-breakers
- Integrated real-time data recorder
- Integrated event logging
- 4Q energy counter
- Measured value simulation

GSP274 - Grid Measurement	
Current/Voltage Measurement	
Measuring method	<ul style="list-style-type: none"> • True RMS (incl. harmonics up to 3 kHz) • Fundamental RMS (only fundamental)
Sampling rate	100 μ s (10 kHz)
Measurement interval	50 Hz: 10 ms 60 Hz: 8.33 ms
Individual samples	Intervals that can be retrieved via function calls in the user application: 100 μ s, 200 μ s, 400 μ s, 800 μ s, 1.6 ms (via block access)
Voltage Measurement	
Number	7 (generator: L1,L2,L3,N / grid: L1,L2,L3,N / busbar Lx,Ly)
Maximum rated voltage	$U_{L-L, RMS}: 480 V_{rms}$ $U_{L-N, RMS}: 277 V_{rms}$
Voltage measuring range	$U_{L-L, RMS}: 5$ to $718 V_{rms}$, $U_{L-N, RMS}: 3$ to $415 V_{rms}$
Accuracy ¹⁾	$\leq \pm 0.15 \%$
Continuous overload	$U_{L-L, RMS}: 1021 V_{rms}$, $U_{L-N, RMS}: 590 V_{rms}$
Short-term overload (10x10 s, Interval 10 s)	$U_{L-L, RMS}: 3637 V_{rms}$, $U_{L-N, RMS}: 2100 V_{rms}$
Input impedance	$> 2 M\Omega$
Current Measurement	
Number	4 (generator: 3x, Generator star/neutral-point: X 1)
Accuracy ¹⁾	$\leq \pm 0.08 \%$
Current transformer rated current	$5 A_{rms}$
Current measuring range	0.01 to $9.5 A_{rms}$
Response threshold	1 mA
Continuous overload	$10 A_{rms}$
Short-term overload (5x1 s, interval 300 s)	$100 A_{rms}$
Apparent ohmic resistance	250 mVA
Frequency Measurement	
Rated frequency	50 / 60 Hz
Reference range	50 Hz: 35 to 65 Hz 60 Hz: 45 to 75 Hz
Accuracy ¹⁾	$\leq \pm 0.004$ Hz
Measurement interval	Updated at each positive zero crossing 1-conductor systems: 3-conductor systems: 50 Hz: 20 ms 50 Hz: 6.667 ms 60 Hz: 16.67 ms 60 Hz: 5.6 ms
Frequency change measurement	Yes

1) Accuracy values as a percentage of the nominal value at 25 °C and reference conditions

GSP274 - Grid Measurement							
Phase Measurement, Asymmetry							
Phase angle	Angles from current phasor to voltage phasor for each phase						
Voltage system	Angles between the voltage phasors						
Asymmetry voltage system	Quotient of negative and positive sequence system of voltages or rated voltage as percent value						
Asymmetry current system	Quotient of negative and positive sequence system of currents or rated current as percent value						
Field rotation direction	Detection for voltage and current system						
Power Measurement – Active, Reactive and Apparent Power							
Measured values	P, Q, S per phase and as total						
Accuracy ¹⁾	≤ ±0.2 %						
Calculation methods	DIN 40110-2, IEC 61400-21						
Measurement interval	Updated at each positive zero crossing <table border="0"> <tr> <td>1-conductor systems:</td> <td>3-conductor systems:</td> </tr> <tr> <td>50 Hz: 20 ms</td> <td>50 Hz: 6.667 ms</td> </tr> <tr> <td>60 Hz: 16.67 ms</td> <td>60 Hz: 5.6 ms</td> </tr> </table>	1-conductor systems:	3-conductor systems:	50 Hz: 20 ms	50 Hz: 6.667 ms	60 Hz: 16.67 ms	60 Hz: 5.6 ms
1-conductor systems:	3-conductor systems:						
50 Hz: 20 ms	50 Hz: 6.667 ms						
60 Hz: 16.67 ms	60 Hz: 5.6 ms						
Energy							
Accuracy ¹⁾	≤ ±0.2 %						
Resolution	1 Ws						
Active energy	Supplied (positive), drawn (negative)						
Reactive energy	Supplied (positive), drawn (negative)						
Type of memory	Nonvolatile (on the module)						
Measurement interval	Updated at each positive zero crossing <table border="0"> <tr> <td>1-conductor systems:</td> <td>3-conductor systems:</td> </tr> <tr> <td>50 Hz: 20 ms</td> <td>50 Hz: 6.667 ms</td> </tr> <tr> <td>60 Hz: 16.67 ms</td> <td>60 Hz: 5.6 ms</td> </tr> </table>	1-conductor systems:	3-conductor systems:	50 Hz: 20 ms	50 Hz: 6.667 ms	60 Hz: 16.67 ms	60 Hz: 5.6 ms
1-conductor systems:	3-conductor systems:						
50 Hz: 20 ms	50 Hz: 6.667 ms						
60 Hz: 16.67 ms	60 Hz: 5.6 ms						
Power Quality							
Voltage	Total harmonic distortion (THD) per phase						
Current	Total demand distortion (TDD) per phase						
Voltage harmonics	Amplitudes of harmonics up to 50th harmonic per phase						
Current harmonics	Amplitudes of harmonics up to 50th harmonic per phase						
Calculation method	EN 61000-4-7						
Measurement interval	50 Hz: Calculation over 10 periods 60 Hz: Calculation over 12 periods						
Digital Inputs – Switch Position Indication							
Number	4 (2 groups each with 2 inputs)						
Signal rated voltages	24 VDC						
Input voltage range (H)	15 to 34 VDC						
Input voltage range (L)	-34 to 5 VDC						
Internal resistance	6.8 kOhm						
Input delay (typically)	1 ms						
Status display (LED)	Green						

1) Accuracy values as a percentage of the nominal value at 25 °C and reference conditions

GSP274 - Grid Measurement**Digital Outputs – Synchronization and Alarming**

Number	4
Signal rated voltages	24 VDC
Output voltage range (H)	18 to 34 VDC
Output current max.	0.5 A
Status display (LED)	Green

Digital Relay Outputs – Grid and System Protection

Number/type	2 changeover contacts
Signal rated voltages	230 VAC, 48 VDC, 24 VDC (not mixed)
Output current max.	Nominal 0.5 A at +24 VDC, DC-13 Nominal 0.5 A at +24 VDC, resistive load Nominal 1 A at 230 VAC, AC-15 Nominal 2 A at 230 VAC, resistive load
Status display (LED)	Green

GSP274 Limit Value Monitoring

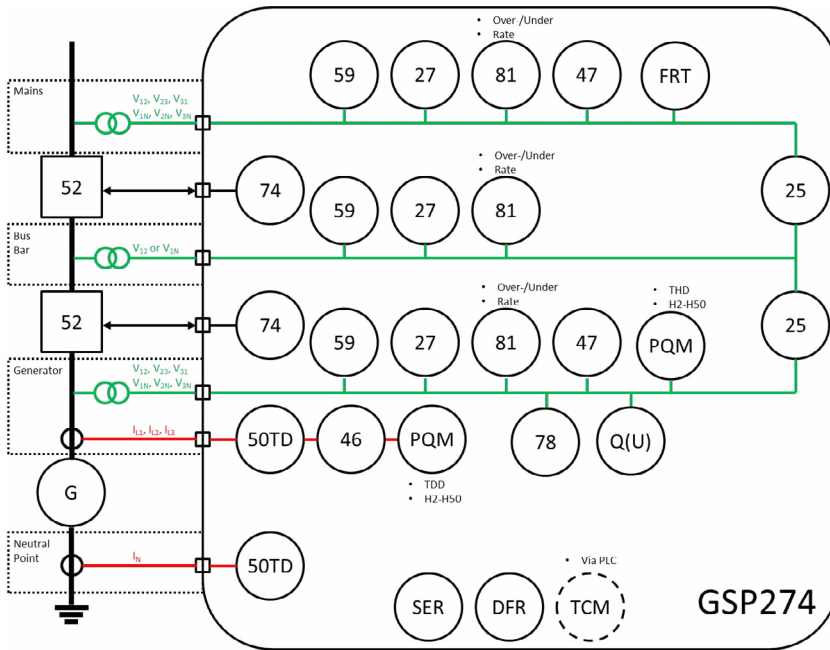

Figure 1: Available protection elements acc. to ANSI IEEE Std C37.2 – 2008 – overview

GSP274 - Limit Value Monitoring		
Undervoltage/Oversvoltage (ANSI 27/59)		
Resolution	0.1 % U_{Rated}	
Delay	0 to 65535 ms	
Evaluated potentials	Phase-to-phase or phase-to-neutral	
Protection elements	U<	Undervoltage warning
	U<<	Undervoltage error
	U>	Oversvoltage warning
	U>>	Oversvoltage error
Underfrequency/Overfrequency (ANSI 81 U/O)		
Delay	0 to 65535 ms	
Protection elements	f<	Underfrequency inner band
	f<<	Underfrequency middle band
	f<<<	Underfrequency outer band
	f>	Overfrequency inner band
	f>>	Overfrequency middle band
	f>>>	Overfrequency outer band

GSP274 - Limit Value Monitoring**Q(U)**

Description	Voltage dependent directional reactive power protection. Used to support the voltage during grid faults. Trips if all three evaluated voltages are below a certain limit (e.g. $0.85 U_{Rated}$) and inductive reactive power is drawn from the power supply grid.
-------------	---

Rate of Change of Frequency – ROCOF (ANSI 81 R)

Description	To calculate the frequency change over time the last 10 (50 Hz) or 12 (60 Hz) frequency samples are linearly interpolated.
-------------	--

Vector Jump (ANSI 78)

Description	Monitoring of sudden phase shifts for detection of sudden load changes or islanding.
-------------	--

Overcurrent (ANSI 50TD)

Resolution	0.1 % of I_{Rated}	
Delay	0 to 65535 ms	
Protection elements	I> I>>	Overcurrent warning Overcurrent error

Time-dependent Undervoltage/Overvoltage Protection (VFRT)

Description	Time-dependent voltage monitoring is triggered if one of the three phase voltages (asymmetrical fault) or all voltages (symmetrical fault) fall below or rise above a curve $U(t)$ configured via interpolation points. Up to 11 time/voltage pairs are available to calculate a grid-code dependent limit curve. Four separate protection functions can be used with different parameter sets. (LVRT, HVRT)
Protection elements	$U(t)a>$, $U(t)b>$, $U(t)c>$, $U(t)d>$, $U(t)a<$, $U(t)b<$, $U(t)c<$, $U(t)d<$

Voltage Asymmetry Monitoring (ANSI 47TD)

Description	Monitoring of the actual asymmetry of the voltage system against the given threshold value. The asymmetry calculation can be configured as ratio of the actual negative sequence voltage to the actual positive sequence voltage (EN 50160) or to the rated voltage.
-------------	--

Current Asymmetry Monitoring (ANSI 46)

Description	Monitoring of the actual asymmetry of the current system against the given threshold value. The asymmetry calculation can be configured as ratio of the actual negative sequence current to the actual positive sequence current (EN 50160) or to the rated current.
-------------	--

Power Quality Monitoring – PQM

Description	Monitors voltage and current harmonics up to the 50th harmonic. Trips if one of the pre-defined limits is exceeded (evaluation per phase).	
Protection elements	THD TDD H_2 to H_{50} H_2 to H_{50}	Total harmonic distortion Total demand distortion Individual amplitudes of voltage harmonics Individual amplitudes of current harmonics



GSP274 - Limit Value Monitoring	
Alarm Relays (ANSI 74)	
Description	Two relays for actuating the circuit-breakers are provided for single fault tolerant grid and system protection acc. to VDE-AR-4105. See Digital relay outputs
Synchronization Test Relays (ANSI 25)	
Description	Digital outputs control up to two circuit-breakers (2 DO per circuit-breaker). They are activated by the GSP module if the synchronization criteria are fulfilled. Pulse or continuous signal can be configured for the actuation. See Digital outputs
Black bus start	Yes
Trip Circuit Monitoring – TCM	
Description	Digital inputs are provided to monitor the actual switching state of the circuit-breakers. See Digital inputs
Time Synchronization	
Basic principle	GSP module is synchronized automatically with the real-time clock of the PLC-CPU. This can be synchronized via the network.
Physical medium	Ethernet (CPU)
Protocols	IEEE 1588 PTP (Precision Time Protocol) SNTP (Simple Network Time Protocol)
Event Logging with Real-time Stamp – SER (Sequence of Events Recorder)	
Description	Monitoring events (configured alarm/protection functions) are stored with a precise time reference when they occur.
Type of memory	Nonvolatile (on the module)
Size	2048 entries
Real-time Data Recorder / Digital Fault Recorder – DFR	
Description	The GSP module is provided with 3 integrated real-time data recorders. One data recorder can be used for recording the synchronization sequence between the generator and busbar and one for busbar and grid. Another data recorder can carry out recordings when triggered by a monitoring function.
Number of channels	16 channels (measured values, digital I/O, calculated values)
Memory depth per channel	40,960 sampling values (4 s at 100 µs sampling rate)
Sampling rate	100 µs, 200 µs, 400 µs, 800 µs, 1.6 ms
Pre-trigger	Yes

GSP274 - Module Properties	
Electrical Safety	
Product standard	IEC/EN 61131-2
Generic standard	IEC/EN 60664-1
Pollution degree	2
Overvoltage category	3
Rated impulse withstand voltage	5 kV
Protection class	2
Approvals / Certificates	
Generator Grid Connection	GER: VDE-AR-N 4105:2018, DIN VDE V 0124-100:2020, VDE-AR-N 4110:2018, FGW TR3 (Rev. 25), FGW TR8 (Rev. 9) UK: ENA G99/1/4:2019 USA: IEEE C37.90:2005
Maritime & Offshore	ABS, BV, DNV, LR, KR, NK, RINA
Ambient Conditions	
Operating temperature	-30 to +60 °C (standard install position)
Rel. air humidity, operation	5 to 95 % no condensation
Storage temperature	-40 to +85 °C
Rel. air humidity, storage	5 to 95 % no condensation
Maximum operating height	2,000 m above sea level (operation up to 4,500 m on request)
Power Supply	
Via backplane	+5 V ≤ 316 mA, +15 V ≤ 21 mA, -15 V ≤ 23 mA
External on the module	24 V 110 mA
System Requirements	
Hardware	All M1 CPU families apart from ME203, SK1 backplane not required
Software	Recommended: M-Base 4.25 / SolutionCenter 2.25 or higher At least M-Base 3.90 / SolutionCenter 1.90 or higher (with restrictions)

Order Codes		
Item	Item No.	Description
GSP274	00019756-00	Grid measurement, protection and synchronization module; 7x In 480V, 4x In 5A; 4x In 5A; 4x In 24V; 4x Out 24V; 2x Out Relay 24/48VDC, 230VAC; U-, I-, P-, Q-, f-measurement; 4Q-energy metering, integrated monitoring/protection functions, harmonic analysis, integrated realtime data recorder (16 channels); sequence of event log with realtime stamp
GSP274 CC	00021759-00	Like GSP274; ColdClimate (❄️)
Accessories		
KZ-GSP274 B+C	00023426-00	Terminal set Phoenix cage clamp/screw (1x KZ 51/03; 3x KZ 51/06; 2x SS76/10) with labeling strip and coding elements