



3D MEMS Acceleration Sensor

The 3D MEMS Acceleration Sensor is a high sensitivity/low noise triaxial acceleration sensor, which can provide simultaneous measurements of acceleration in 3 mutually perpendicular axes.

Micro Electronic Mechanical Systems (MEMS) acceleration sensors provide a compact and effective method for making static and dynamic measurements of acceleration. The MEMS technology uses the capacitance between plates to measure acceleration. Mass at the end of a plate is affected by acceleration, thus deflecting the plate and changing the capacitance of the device. This capacitance is converted to produce a current output proportional to acceleration.

Bachmann offers this sensor to provide a 3D measurement of acceleration. The output is via a standard 5 pin M12 connector, giving retrofit compatibility with the Bachmann Monitoring 2D MEMS Acceleration Sensor.

Uses of the Bachmann Monitoring 3D MEMS Acceleration Sensor are in the field of structural motion measurement. The output can be used for blade unbalance assessment (mass and aerodynamic), structural health monitoring and tower natural frequency assessment.

Mounting is done by means of M4 screws – either on existing threaded holes or on a corresponding adapter plate, which can be fixed e.g., by means of mounting magnets – (see accessories).

Part Type Designation	Part Number
BAM-3D-MEMS-M12-V01	00037571-00

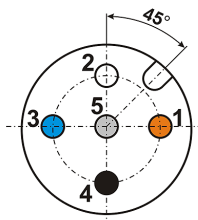

Pin	Color	Function
1	Brown	Supply voltage
2	White	Signal 1 (X)
3	Blue	GND
4	Black	Signal 2 (Y)
5	Gray	Signal 3 (Z)

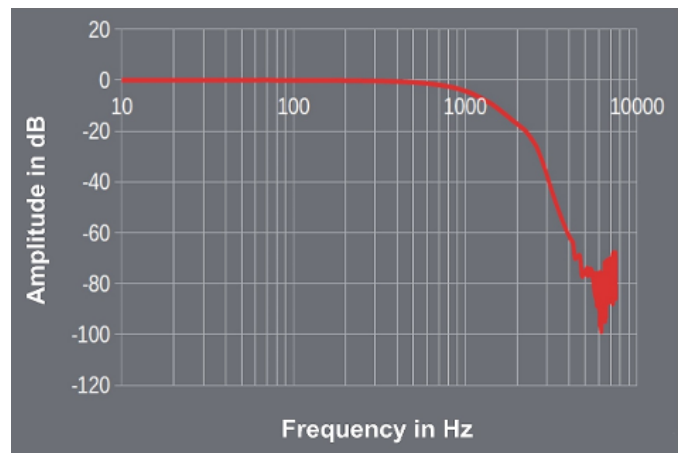

▼ Amplitude response

BAM-3D-MEMS-M12-V01 Acceleration Sensor

Technical Data		
Supply voltage	9 V DC to 32 V DC	
Output signal	4 mA to 20 mA	
Zero Signal Offset ¹⁾	12 mA	
Offset Error ²⁾	±1 % (FS)	
Offset Temperature Sensitivity ³⁾	Max. 0.15 mg/K	(Max. 1.5 mm·(s ² ·K) ⁻¹)
Sensitivity ³⁾	4 mA/g	(0.41 mA (m·s ⁻²) ⁻¹)
Temperature Sensitivity ¹⁾	0.01 %/K	
Noise ³⁾	25 µg / √Hz	(0.25 mm (s ² √Hz) ⁻¹)
Measurement range ^{3), 4)}	-2.0 g to 2.0 g	(-20 m·s ⁻² to 20 m·s ⁻²)
Frequency Range	0 Hz to 860 Hz (3 dB)	
Cross-sensitivity ¹⁾	≤ 1 %	
Non-linearity ¹⁾	0.1 % FS	
Load	Max. 100 Ω @ 9 V < U _B < 12 V Max. 250 Ω @ 12 V < U _B < 24 V Max. 800 Ω @ 24 V < U _B < 32 V	
Max. power consumption	2 W	
Temperature range (storage, transport, operation)	-40 °C to +85 °C	
Protection class	IP67	
Number of axes	3	
Wiring	M12 (m), 5 contacts, A-coded	
EMC	IEC 61000-6-2, IEC 61000-6-4, IEC 61000-4-2, -3, -4, -5, -6 and -8	

¹⁾ Typical value

²⁾ FS here denotes full scale deflection.

³⁾ g denotes the normal acceleration of free fall 9.80665 ms⁻² – in approximation 10 ms⁻².

⁴⁾ Per axis. For the axis aligned the direction of the acceleration of free fall (g), the sum of the effective accelerations must not exceed the measurement range.

Order Data – Accessories

Part Type Designation	Part Number	Description
Sensor cable	00032520-00	12G-UNG 5POL 15m BK AIX
Adapter plate	00031702-00	Sheet for die-cast aluminum housing
Magnet system	00031832-00	43 mm × 31 mm rubberized, 2 female threads M4
Cylinder head screw	00031863-00	M4 × 25 ISO 4762 with hexagon socket IS3 stainless steel A4/70
Cylinder head screw	00032023-00	M4 × 8 ISO 4762 with hexagon socket IS3 stainless steel A4/70
Cable holder	00031848-00	Magnet d = 22 mm rubberized

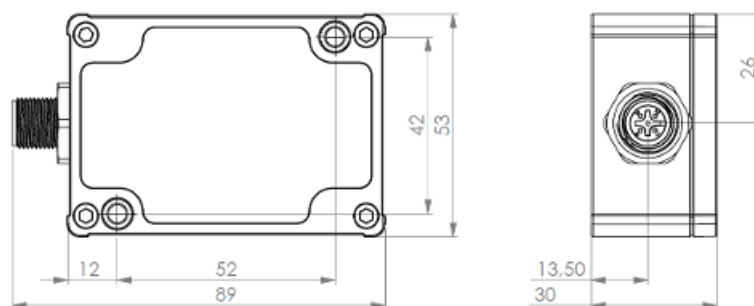

▼ Dimensions in mm