





MODULAR SAFETY CONCEPT

Ceramic sinter presses in line with new Machinery Directive

Dorst is a company based in the Bavarian town of Kochel am See, Germany, and is one of the leading international suppliers of machines and plants for the manufacture of ceramic and powder metal components. The manufacturing systems and presses have a modular design and are constructed to meet the specific requirements of the customer. Dorst was on the lookout for a similar level of flexibility for the automation and safety control of its plants, and found it in the Bachmann M1 automation system with its integrated safety package.



With around 400 employees worldwide, Dorst is one of the globally recognized experts in applications involving the forming of ceramics and metal powder. The company particularly specializes in raw material preparation and forming technology. Their presses and manufacturing systems are therefore indispensable for many industries.

Individual solutions

Dorst has always been one of the leading suppliers for the tableware and the sanitary ware industries. Spray dryers for producing pressing granulate, isostatic automatic presses for producing flatware, as well as pressure casting systems for the tableware and the sanitary ware industry using “plastic filters” instead of plaster molds have made history. The plants are as individual as the products that are made on their machines. This also means that hardly one configuration

is the same as the other. “Depending on the complexity and form of the tableware – consisting of round, irregular and even more complex geometries – up to six machining stations for deflashing, grinding, sponging and polishing are used at the outlet of the manufacturing system,” explains Herbert Gröbl, development manager for control technology at Dorst. He also adds: “This does not include other optional units such as for foot machining.” This flexibility required on the market is also one of the challenges placed on the automation. “The modularity of the Bachmann M1 automation system,

particularly with regard to the integration of the safety function, was therefore one of the key factors why we decided to use it,” Herbert Gröbl recalls.

Safety in series

The modular machine function in the Bachmann safety system, that was specially developed for series machine building, supports the developers in the simple implementation of safety systems in the plant series and machine options. With conventional safety systems, the later installation of expansions requires at least a manual integration of additional safety modules, the re-installation

of the safety software and in the worst case even another acceptance testing of the machine. Version problems in software and hardware lead to delays, and wired solutions here are even more time consuming. “Thanks to this functionality in the Bachmann system we already supply all the program sections,

including all extensions on the safety controller with the basic machine,” Herbert Gröbl explains a key benefit. The later installation of a new function then only requires the connection of the module control cabinet to the system bus and an activation of the machine section via the engineering software or visualization.

Maximum safety required

The Dorst hydraulic presses for the manufacture of complex metal powder components, such as the TPA/3 HP series systems, generate pressing forces up to 16,000 kN.

» The simple integration of the safety solution impressed us. «

*Herbert Gröbl,
Head of development for control
technology at Dorst*



The company is based in Kochel am See, Germany, with 400 employees and offers intelligent system solutions for machines and plants for manufacturing ceramic and powder metal products. Dorst plants are in operation in 70 countries worldwide, resulting in an export quota of 80 %.

➔ www.dorst.de



▲ Individual solutions, modular design: Dorst PH 450 isostatic production system with machining stations for the manufacture of flat tableware and bowls with different contours.

The guard doors on these presses are not interlocked but protected by inductive safety switches with SIL3 Performance Level “e”. Besides the optimization of the production process, the safety of man and machine are also given priority: “During operation the system is completely closed. The guard doors can only be opened if the plant is shut down and all axes are in a safe position,” Herbert Gröbl explains. Naturally the machine must also be shut down immediately and with maximum delay when the emergency-stop button is actuated or the process monitoring indicates a critical fault.

“The simple integration of the safety solution in the M1 automation system really impressed us here,” Herbert Gröbl explains. The hardware is seamless and separate diagnostic I/Os become unnecessary, thus

keeping the hardware and wiring effort down to a minimum, saving costs and reducing sources of error. The cycle-precise access to the error and diagnostic outputs of the PLCopen safety function blocks and the direct use of relevant variables in other applications such as the visualization are generally available. This makes it very easy to display both the current operating state in the highest ▶▶

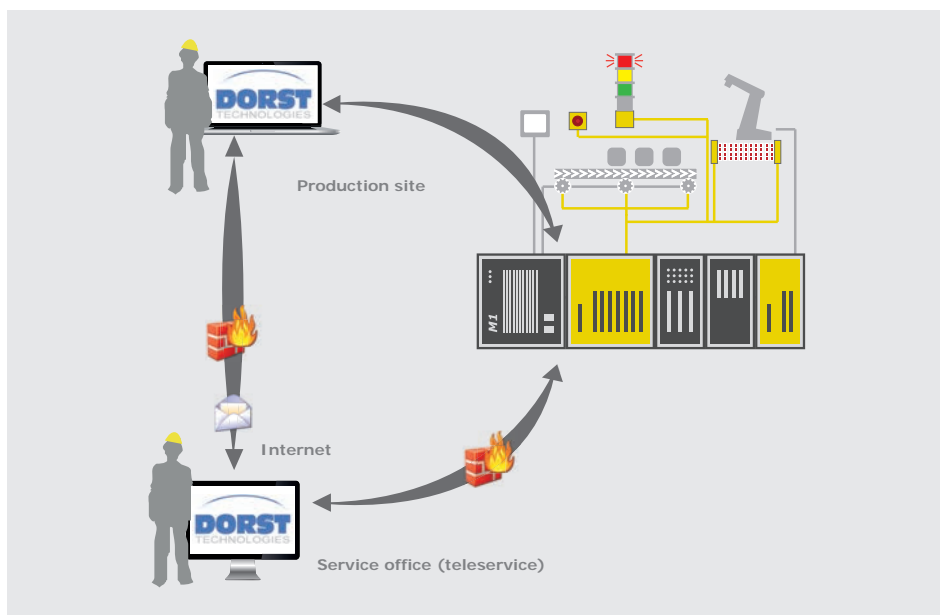

◀ Safe solution: Machine accesses by different people in different locations, for example during fault diagnostics and rectification are managed safely with ingenious security measures.



▲ EP series from Dorst: The new generation of servo motor powder presses with a press force of 150 kN up to 1,600 kN.

►► degree of detail as well as the precise status of the application in the event of a fault. This therefore also saves time during programming: “The individual elements of our plants can be assigned easily to the safety functions,” the development manager describes. “Through the use of function blocks, the so-called safety compounds, clean and clear structuring are ensured. The fact that we can use these blocks in different projects and thus implement them quickly in similar machines and plants is of key importance to us.”

Simple remote maintenance of the safety solution

The Dorst systems are in operation in over 70 countries worldwide, making the maximum possible level of remote plant maintenance essential. The SolutionCenter engineering tool offers the service technician optimum diagnostic options for this: “Even in first and second level support, online debugging is also possible in safe operation,” Herbert Gröbl describes an important function. As all program sections, including the descriptions are stored on the safety controller,

► Minimum programming effort: The modular machine safety function keeps the effort required for configuring plant options to a minimum and significantly simplifies maintenance and later expansions.

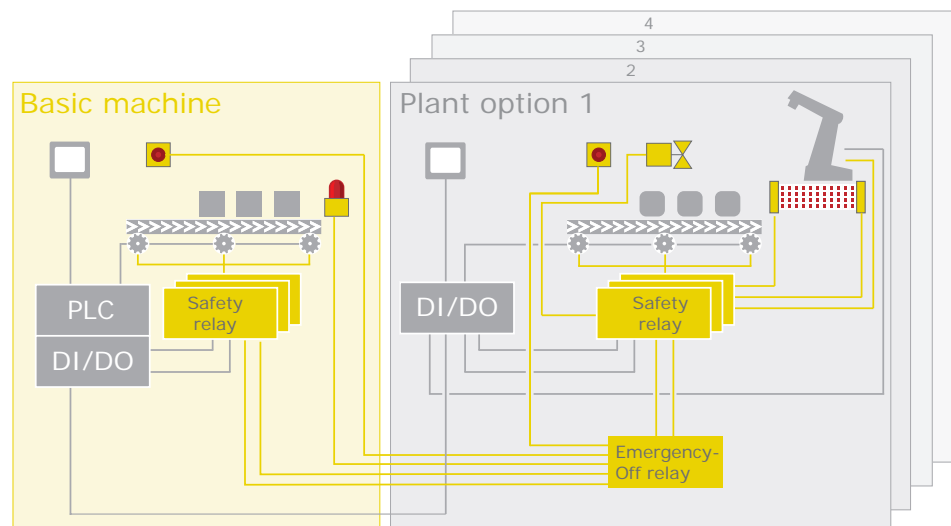



»The modularity of the Bachmann M1 automation system, particularly with regard to the integration of the safety functions, was one of the key factors why we decided to use it.«

*Herbert Gröbl,
Head of development for control technology at Dorst*

this is imported by the SolutionCenter. This ensures that a different version is not accidentally used for debugging – creating additional problems.

Secure access

The many access options to the machine controller and the safety system naturally require a high level of security in communication. The layer-based security approach in the Bachmann system uses different functions in every controller for access protection and control. The basis for this is provided by a sophisticated user administration system with a permissions system included up to the variable level. An open interface for expansions also enables additional user requirements to be covered. A comprehensive user administration system not only offers protection from manipulation and unauthorized access.

Individually assignable user permissions reduce the risk of operating errors and protect the patent and IP rights of the plant application. The non-volatile storage of safety-relevant user accesses such as for the reprogramming of the safety controller provides this data also for keeping evidence in the event of accidents or guarantee claims.

Future-proof position

“Being a leader means being innovative.

Being innovative means researching and developing for the demanding requirements of our company.” This is written in Dorst’s corporate philosophy, to which the company is committed. In close collaboration with Bachmann, it has thus been possible to produce cutting edge solutions for safe automation. Solutions that show that good safety technology is economical, not only ensuring safer operation but already paying for itself in the development phase.

Bachmann Safety Developer – a safe programming tool

- Simple import and export of non-safety functions and variables
- Version management integrated in the programming environment
- Storage of complete projects on the safety controller
- Comprehensive time stamp recording of events in safety and non-safety applications
- Online monitoring possible in safe operation
- Active prevention of malicious or accidental manipulation of projects
- Risk-free remote access via Intranet and Internet
- Integrated user administration with access authorizations

